

DESCRIPTION

The 7500P Mag Meter is a successful combination of the most advanced electromagnetic flow metering technology with the simplicity and ruggedness of proven batching systems for industrial applications.

Based on Faraday's Law of electromagnetic induction, the 7500P Mag Meter can accurately measure and control most of the batching needs in the industrial market. The completely open cross-section flow tube design with no moving parts makes this meter the ideal device for batching of a wide range of industrial fluids including concrete process water applications.

Where other metering technologies fail due to the presence of solids in suspension in the process water, the 7500P is designed to perform for many years of trouble-free operation with an accuracy of $\pm 0.5\%$ or better.

The built-in *Pulse Scaler* features easy-to-use rotary switches for batch accuracy compensation, making the 7500P the most straightforward metering system available in the industry.

OPERATION

The 7500P Mag meter is a stainless steel flow tube with an internal isolating lining. Two electromagnetic coils are located outside the flow tube, diametrically opposed to each other and protected by a carbon steel housing. Two electrodes, inserted into the flow tube, are positioned "flush" with the internal diameter of the tube and perpendicular to the coils. The coils are energized by a pulsed DC voltage provided by the electronic converter, and a magnetic field is generated across the flow tube section. According to Faraday's law, when this magnetic field is "cut" by the conductive liquid flowing through the meter, a voltage is generated in the liquid. This voltage is directly proportional to the liquid flow velocity, and therefore to the actual volumetric flow rate of the liquid. The electronic converter measures this voltage, processes the signal, and provides two digital pulse outputs, scalable to the desired volumetric value. These digital pulse outputs can be connected to a batch controller, a totalizer display unit for monitoring purposes, or to both devices simultaneously.

Operation of the 7500P is not affected by a moderate presence of most suspended solids in the liquid. Variations of liquid temperature, viscosity or density have no influence in its principle of operation. A set of convenient, field proven pulse scaler rotary switches are provided for easy and straight-forward batch accuracy compensation.



FEATURES

- Unaffected by the presence of most suspended solids in the liquid.
- Open cross-section design: no pressure loss, no moving parts, no maintenance required.
- Pulsed DC magnetic field for maximum zero point stability.
- Rugged, Surface Mount technology electronics for reliable, long life operation.
- NEMA 4 standard enclosure.
- Two standard pulse outputs: solid state relay and open collector output, compatible with most of existing Batch Controllers and/or Totalizer Displays.
- Standard $\pm 0.5\%$ of rate accuracy.
- $\pm 0.2\%$ repeatability.
- Built-in rotary switches for easy batch accuracy compensation.

Product Data Sheet

SPECIFICATIONS

Detector	
Working Pressure	150 psi (10 bar)
End Connections	ANSI 150# carbon steel flanges
Flow Tube Material	AISI 316 stainless steel
Housing and Flange Material	Carbon steel, enamel paint finishing
Liner Material	PTFE
Electrode Material	Alloy C
Maximum Liquid Temperature	212° F (100° C)
Amplifier	
Power Supply	110 V AC ±10%, 5 VA
Coil Excitation	Pulsed DC, 7.5 Hz
Minimum Liquid Conductivity	5 micromhos/cm
Maximum Output Frequency	10 khz
System Accuracy	±0.5% of rate
Repeatability	±0.2%
Enclosure	Powder coated cast aluminum, NEMA 4
Mounting	Meter mounted only
Environmental	-4...122° F (-20...50° C)
Output 1	Solid state relay up to 230V, 500 mA
Output 2	Opto-isolated open collector, 50 mA @ 24V DC
Flow Direction	Unidirectional
Pulse Width	50% duty cycle
Cable Connections	Two 1/2 in. NPT cord grip

DIMENSIONS

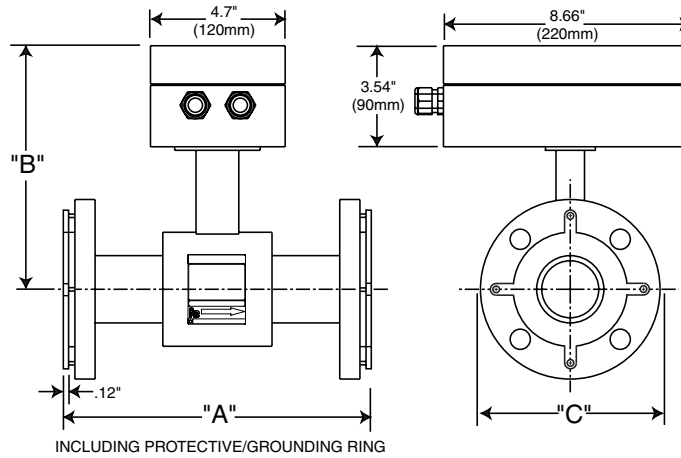

Meter Size	A in. (mm)	B in. (mm)	C in. (mm)	Flow Ranges gpm (lpm)	
				min.	max.
1/2 in.	6.9 (175)	8.1 (207)	3.5 (89)	1 (3.8)	20 (76)
1 in.	9.1 (231)	8.1 (207)	4.3 (108)	3 (11.4)	80 (303)
2 in.	10 (254)	9.1 (232)	6 (152)	10 (37.9)	320 (1211)
3 in.	12 (305)	9.8 (250)	7.5 (191)	22 (83.3)	690 (2612)
4 in.	14 (356)	10.1 (257)	9 (229)	40 (151.4)	1300 (4921)